



**NDS**<sup>®</sup>  
We put water in its place

**Contractor  
Solutions**

## Contractor Resources & Product Overview



**50**  
SINCE 1972

YEARS AS YOUR KNOWLEDGEABLE  
AND TRUSTED PARTNER IN WATER  
MANAGEMENT SOLUTIONS.

[ndspro.com](https://ndspro.com)

MADE IN  
**USA**





Since 1972, NDS has been producing plastic drainage and landscape products. From the beginning, our commitment to leading the industry has been unwavering, leading to remarkable innovations and state-of-the-art products that fit every environment, every schedule, every need.

## 1970's

Introduced the first plastic catch basin

- Plastic grates
- Channel drains

## 1980's

Expanded drainage product offering along with national sales & distribution

- New basin grates
- Additional channel drains

## 1990's

Focused on growth including:

- 18" & 24" Basins
- Pro Channel
- Metal grates

## 2000's

Invested in new product innovations:

- Dura Slope Pre-sloped Trench Drain
- Permeable Paver Systems

## 2010+

Expanded product lines & partnerships:

- FILCOTEN Fiber-reinforced Trench Drains
- Dura Flo HD
- Control Zone Kits





# Table of Contents

## 2 Contractor Value Proposition

## 4 Contractor Resources

- Home Drainage Center
- Video Library
- Online Calculators
- Downloads, Guides & Case Studies
- Doctor Drainage
- DesignWorx™
- Field Support
- Training & Certification
- Sales & Marketing Support

## 14 Drainage

- Flo-Well®
- EZflow®
- Catch Basins & Grates
- Pop-up Emitters
- Channel & Trench Drains

## 22 NDS® StormChambers®

- Underground Stormwater Management

## 24 Permeable Pavers

- Grass & Gravel Paver Products

## 25 Landscape

- Root Barrier Panels

## 26 Professional Irrigation

- Point Source & Dripline
- Dura Flo™ Dripline & Accessories

## 28 Valve & Meter Boxes



# Our Brand Promise:

It comes down to three things – it's at the center of everything we do.

1

---

**Knowledge and Expertise.** NDS is your knowledgeable and trusted partner for the best in water management solutions.

---

2

---

**Product Innovation and Performance.** Our products are engineered and produced for performance, durability, ease of installation and the efficient use of resources.

---

3

---

**Service and Support.** We provide the service and support to ensure that you are successful.

---



## We Are Vested in Your Success

We want you to benefit from our knowledge and expertise. That is why we not only provide products to meet your needs, we make sure they perform, are easy to use, and we offer the most comprehensive set of online tools, design, sales and marketing support to help you succeed with your projects and your customers.

It's easy to find NDS. Our products are sold at over 4,000 wholesale distributor locations.



# NDS® Has the Most Comprehensive Line of Water Management Products

All are carefully engineered to offer maximum performance and designed with features that make them easier to handle and install.

**Catch Basins, Grates and Pop-up Emitters.** A complete line for residential and commercial stormwater management. Grates are available in a variety of patterns, colors and materials, including solid cast brass and chrome options for high-profile locations.



**Trench and Channel Drains.** Channel drain solutions to meet every project and volume need including **Profile Channel Drains** ideal for large to small volumes of water and **Pro Series Channel Drains**, a lightweight, flexible system for commercial applications.

Trench Drains solutions include **Dura Slope™** a pre-sloped, patented system for residential, commercial and municipal drainage needs and **Filcoten®**, a high-performance fiber-reinforced concrete solution designed for heavy loads.



**Flo-Well® Engineered Dry Well.** Gravel-free, easy-to-install alternative to a traditional dry well that outperforms a traditional dry well too – offering up to 250% more detention volume.



**EZflow® Gravel-Free French Drain.** Installs in half the time of traditional gravel systems, EZflow is ideal for French drains, retaining walls, foundations and basements/crawlspace.



**NDS StormChambers®** Strong and easy to maintain. They are an ideal solution for stormwater detention and/or infiltration providing easy installation and design flexibility.



**S&D Fittings.** PVC fittings and accessories including elbows, tees, wyes and downspout adapters. All available in common sizes and conform to applicable ASTM standards for PVC S&D fittings.



**Permeable Pavers.** An alternative to traditional paving methods they create a strong grass or gravel surface that can support heavy vehicles while maintaining permeable surface areas reducing stormwater runoff.



**Landscape/Root Barriers.** Directs root growth from shrubs and trees downward, decreasing the roots potential to disrupt nearby hardscapes, walls or foundations.



**Professional Irrigation.** Efficient drip irrigation products offering complete, system-oriented watering solutions for the green industry.



**Valve & Meter Boxes.** Available in a wide variety of sizes, colors and designations, NDS valve and meter boxes and lids contain UV inhibitors for sustained durability and performance in direct sunlight.



# Contractor Resources

NDS® provides the most resources anywhere to help you identify and solve drainage problems in the landscape. We're your knowledgeable and trusted partner that wants to help you get the job done right! **Start at [ndspro.com](http://ndspro.com), call Doctor Drainage or get in touch with a field representative today!**

## Home Drainage Center – Find Solutions to Common Problems

### Step 1 > Identify the Problem

Select from most commonly encountered drainage problems:

- Water on patio/pool deck
- Water in basement/crawl space
- Water on driveway
- Downspout runoff
- Water in planter area
- Water in walkway
- Water in yard
- Neighbor runoff



### Step 2 > Find the Solution

Low, medium & high capacity solutions provided for each product.

See our low, medium and high capacity solutions to each common problem along with an explanation of why each may be the most appropriate approach for your situation.

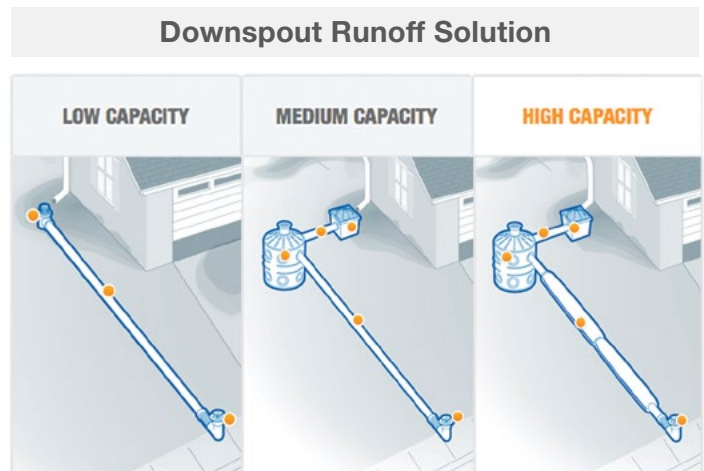



## Step 3 > Review the Installation Instructions

Review the man hours, material costs, tools, instructions and shopping lists:



Man hours to get the job done

**10 - 12 Hours**  
**Total Man Hours**

We estimate the amount of time and labor involved based on a 40-year old male hand-digging all trenches and holes.



Estimated materials cost

**\$395 - \$475**  
**Material Cost**

A summary cost for materials is provided based on shelf prices of NDS products and supplementary products such as pipe.



Tools needed



Shovel

Level

Hammer

Saw

Duct Tape

Wheelbarrow



Email instructions & shopping list

Comprehensive instructions and the materials list will be sent.

## Step 4 > Get what you need

Select your products and find out where to get them.

Find the products you need at **over 4,000 wholesale** distribution locations and with **over 400** Drainage showrooms where knowledgeable sales staff are available to help answer questions.

Shop your local supplier or use our "Where to Buy" tool on [ndspro.com](http://ndspro.com).



### Where to Buy

1 You are a

Professional

2 Your location is

63104

3 You are looking for

Drainage

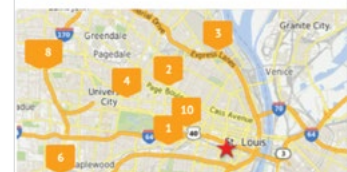

## Tools That Educate & Help You Solve Drainage Problems



### Video Library

Over 70 videos in our library cover everything from our drainage course to product overviews, drainage solutions, irrigation solutions and even testimonials from other contractors.

- **NDS Drainage Course**
- **Product Overviews**
- **Driveway & Patio Solutions**
- **Downspout, Basement & Planter Solutions**
- **Yard Solutions**
- **Professional Irrigation**
- **Permeable Pavers**



### Online Calculators

Want to know how much runoff to expect from a 1" per hour storm event on a 600 SF roof draining to a single downspout? Use our calculators to find out!

- **Flo-Well® Calculator**
- **Drainage Calculator**
- **EZflow® Calculator**
- **Dripline Calculator**
- **Load Rating Recommendations**

#### Drainage Calculator

##### Step 1:

Enter the Square Feet Drained:

##### Step 2:

Choose the Coefficient of Runoff:

##### Step 3:

Choose the 25 Year Rainfall

Note: To get your 25 Year Rainfall, [click here to view the US 25-year rainfall map.](#)

##### Step 4:

Press the Calculate button for results

##### Step 5:

View your results below

###### Liquid Flow:

0 Gallons per Minute (GPM)  
0 Cubic Feet of Water per Second

###### Volume of water to be stored:

0 Gallons  
0 Cubic Feet



## Personal Support to Ensure Your Success



### Downloads, Guides & Case Studies

We have you covered with catalogs, brochures, product sheets, specifications, construction details and more.

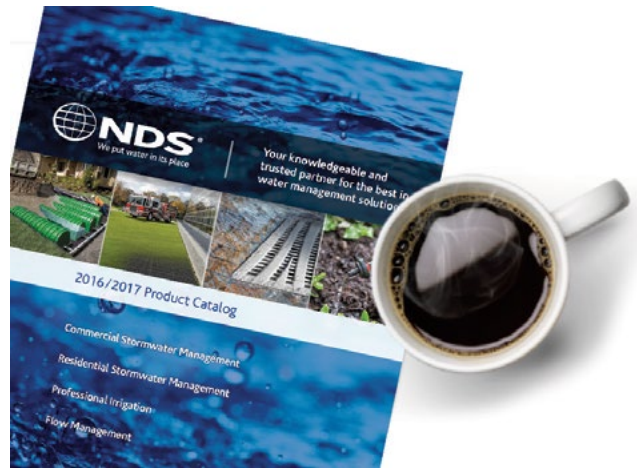

### Doctor Drainage

**Have a Question?** Ask Doctor Drainage. Available by phone or email, our drainage expert is there to help. Or watch Doctor Drainage videos online for detailed overviews of products, installations and system solutions.

**Call: 888-825-4716**

**Email: [DrDrainage@ndspro.com](mailto:DrDrainage@ndspro.com)**

Our entire sales and technical teams are extremely knowledgeable and are there to help you when you need it.



## Personal Support to Ensure Your Success



NDS civil engineers and expert technicians are ready to partner with you to make your project successful. Our team will work with you to assess the feasibility of incorporating NDS products. Supply your drawing and we will evaluate and help you with preparation of your submittal drawings and specs to align with best stormwater practices and save cost.



**Call: 888-825-4716 | [ndspro.com/submityourdesign](https://ndspro.com/submityourdesign)**



### Field Support

NDS has staff in the field to support your projects today. Contact us to find your nearest representative and we'll get you the help you need.



### NDS Stormwater Drainage Tools

- Connects contractors with NDS drainage tools that help them plan, buy and install drainage systems
- Quick access to NDS resources





# Professional Drainage Contractor Certification & Training



## Professional Drainage Contractor Certification

Our goal is to train and certify an army of expert drainage professionals. To this end we developed a comprehensive and intensive Professional Drainage course.

Upon successful completion and evaluation, trainees can earn an NDS Certification and use it to let your customers know you are a trained professional.



**As a Certified or Preferred Contractor Partner, you'll also have access to customized marketing materials, support and tools.**



## Training

NDS® provides expert training for contractors at many wholesale distributor events. The 21st Century Landscape Drainage course presents current industry standards and is recognized by the National Association of Landscape Professionals (NALP) for 1 Continuing Education Unit (CEU) per hour of instruction.



## Training & Certification



### Certification Course Topics

#### The half-day course covers the following:

- **Drainage Fundamentals** – Explore the roots of landscape drainage including rainfall and weather patterns, surface types and runoff, subsurface groundwater, soils and soil properties, landform, slope and more.
- **Common Problems & Solutions** – Learn how to identify, evaluate and solve the most common landscape drainage problems with a comprehensive NDS solution.
- **Basic System Design** – Learn effective methods of calculating peak-flow runoff and detention volume to design a fully functioning drainage system including runoff capture, filtration, conveyance, detention, infiltration and overflow.
- **Regional Design Examples** – We bring it all home by presenting real-world drainage problems, the necessary considerations and steps to provide a comprehensive design solution, and how to put all the components together for an effective installation.
- **NDS Resources** – Introduces the many tools and resources NDS has available to contractors to understand the nature of drainage issues, provide effective solutions and position themselves to grow their drainage-service business. Also presents the proactive efforts of NDS to raise public and industry awareness of drainage problems and solutions.

Course availability is limited. Check with your local NDS Sales Manager or Representative to see if a course can be arranged in your region. Certification is not guaranteed; trainees must pass an evaluation based on presented material.



Drainage Fundamentals



Common Problems & Solutions

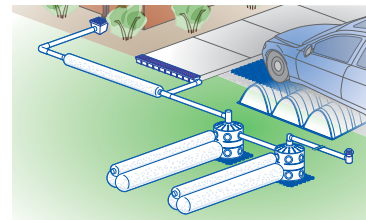

Basic System Design



Regional Design Examples

## Sales and Marketing Support to Grow Your Business



### Partner with NDS

**NDS offers two participation levels:**



**Preferred Partner Listing** on [ndspro.com/contractors](https://ndspro.com/contractors) – Preferred partners receive top billing when homeowners search for contractors in their area.

**100,000 NDS WEBSITE VISITS EACH MONTH**

**Digital Marketing Support** which includes website optimization services such as drainage search keywords, online digital listings and lead generation.

**Case Study Access** to feature your company's projects on [ndspro.com](https://ndspro.com)\*\*

**\$500 Annual Credit for Print On Demand Marketing Materials** customized with your logo. Includes post cards, yard signs and door hangers.

**Access to NDS Digital Content** to feature in your own materials and website.\*\*\*

**Preferred Contractor Requirements:** At least one staff employee successfully completes the NDS Professional Drainage Contractor Certification Course. Minimum \$15K (in the last 12 months) NDS drainage purchases\*. Promotion of drainage services and solutions, featuring NDS drainage products on your company website\*\*\*\*

\*must provide documentation of purchases \*\*must provide project details, images and NDS products used.

\*\*\*NDS must be credited \*\*\*\*NDS will consult and provide digital content, copy and images to enhance their landing page as needed.



**Certified Partner Listing** on [ndspro.com/contractors](https://ndspro.com/contractors)

**Access to Print On Demand Marketing Materials** customized with your logo. Includes post cards, yard signs and door hangers.

**Access to NDS Digital Content** to feature in your own materials and website.\*\*\*

**Certified Contractor Requirement:** Completion of the NDS 4-hour in-person certification course or attendance of one in-person training module and completion of the balance of modules online.



## Sales & Marketing Support to Help Grow your Business



### Customized Marketing Materials & Collateral

NDS offers sales collateral including yard signs, door hangers, brochures and post cards, all customizable with your business logo to market your professional landscape drainage expertise. Contact your NDS Sales Manager or Representative today to see the latest designs, review the fee structure and get access to our print-on-demand website.



Door Hangers



Yard Signs



Homeowner Brochure



Postcards



### Digital Marketing Package

#### Will homeowners find you when they search for help?

The NDS digital contractor package includes website listings and keyword dense copy for your website to drive homeowners to your business. Contact your NDS Sales Manager or Representative today to learn more information on how to take advantage of this program.



## Sales & Marketing Support to Help Grow your Business

### Find a Contractor Listings

When homeowners need a contractor we will help connect you by listing your business on the [ndspro.com](http://ndspro.com) website.

Over 70% of our visitors are homeowners looking for help with a drainage problem. We average 100,000 homeowner visits each month!

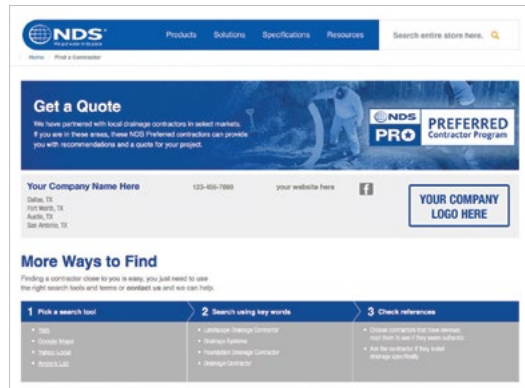

### Learn more about online Professional Drainage Contractor Certification

Visit [www.ndspro.com/for-contractors](http://www.ndspro.com/for-contractors)

Access certification courses on the NDS training platform and complete on your own time and schedule.

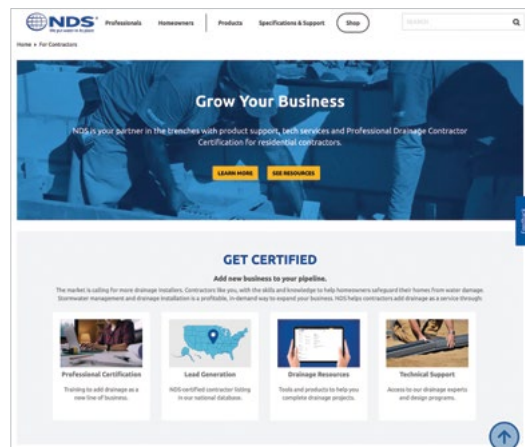

# Drainage

**NDS® has been the stormwater drainage leader for over 50 years.**

We are proud to say that NDS is the #1 installed residential/light commercial stormwater drainage brand and the #1 most specified residential/light commercial plastic catch basin. And most of our products are made here, in the U.S.A.



**Catch Basins, Grates & Accessories**



**Channel & Trench Drains**



**EZflow® Gravel-Free French Drain Systems**

## NDS has the Largest Portfolio of Products in the Drainage Industry

NDS®	Drainage SKUs
Basins & Grates	186
Dura Slope Trench Drain	122
Profile Channel	97
DrainTech	84
PVC S&D Fittings	82
Pro Series Channel	44
Brass & Chrome Grates	20
EZflow	11
Flo-Well	6
<b>Total</b>	<b>652</b>

Others	Drainage SKUs
Competitor 1	46
Competitor 2	69
Competitor 3	30
Competitor 4	83
Competitor 5	62

**OVER TWICE AS MANY PRODUCTS AS OUR TOP 5 COMPETITORS COMBINED!**



# Only NDS® has...

## MORE Catch Basin & Channel Drain Sizes

NDS offers, 6" round, 9", 12", 18" and 24" square Catch Basins & Grates, and, offers 1", 3", 4", 5", 6", 8" and 12" Trench & Channel Drain Widths.



## MORE Drainage Grate Design Options

NDS offers decorative grate options – in plastic and metal. A wide variety of designs offer beauty and function in multiple colors & finishes.

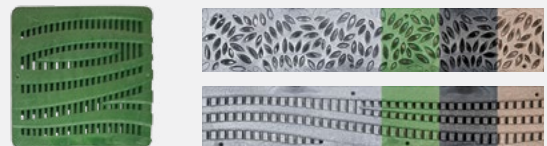

## MORE Grate Materials, Colors & Finishes

NDS offers grates in iron and steel for strength and beauty. Along with chrome and brass in satin and polished finishes.

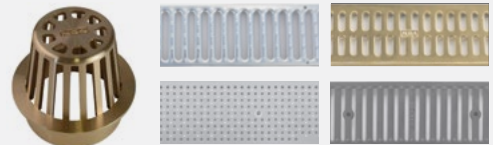

## EXCLUSIVE Products

EZflow® is an engineered and gravel-free alternative to a traditional French Drain system.

Flo-Well® engineered dry well presents an easy-to-install and sustainable solution for managing stormwater runoff.

NDS StormChambers® are the most cost-effective chamber solution on the market, offering a lower-cost alternative to drainage pipes for conveyance, with the added benefits of groundwater recharge and water quality enhancement.



## EXCLUSIVE Accessories

Catch basin filters for 9" and 12" basins to prevent dirt & debris from clogging the system.

Swivel Fit Variable Angle Fitting – eliminates extra fittings and makes it easy to work around obstacles and corners.

New Downspout Grate sheds debris and prevents splashing and runoff overshoot.

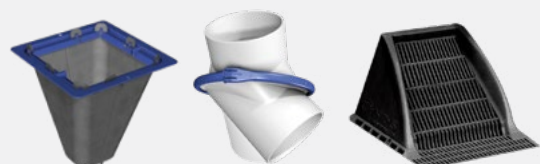

## Flo-Well®

With the Flo-Well®, water can now be discharged into the subsoil rapidly and easily. Unlike competitive systems, there is no need for piping systems to transport stormwater to a far-off discharge point, eliminating the need for large, heavy equipment, considerable excavation of landscaped areas and the large labor costs those systems incur. With Flo-Well, water dispersion is easier than ever.



### Options

Larger 9" or 12" grates can be added to Flo-Well to manage surface water.	Ideal as a stand-alone drain:	Ideal as a stand-alone reservoir:
<p><b>This option is ideal for draining:</b></p> <ul style="list-style-type: none"> <li>· Golf course areas prone to puddling</li> <li>· Playground areas under slides &amp; swings</li> <li>· Outdoor drinking fountain runoff</li> <li>· Outdoor showers at beaches</li> <li>· Wash-down areas</li> </ul>	<p><b>Holds over 48 gallons.</b> Or, connect to existing system for increased drainage capabilities</p> <p>Disturbs only 4 square feet of turf to install</p> <p>Requires less than 10 cubic feet of soil removed to bury</p> <p>Measures only 24" in diameter by 28.75" high</p> <p>Weighs only 22 pounds</p>	<p>Collect and hold rainwater for lawn &amp; garden irrigation (used with a pump connected to a garden hose)</p> <p>Connect Flo-Well to rain gutters using a catch basin &amp; grate below each downspout (see drawing)</p> <p>Ideal solution for arid areas impacted by drought</p> <p>Reservoir for pond and waterfall recirculation pumps</p>

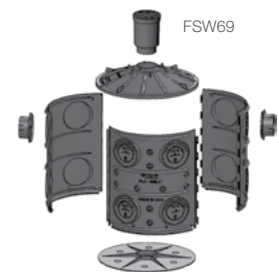

### Stackable & Expandable

Flo-Well® can be used individually, connected in series or in any array, and can be stacked up to 4 units high (with center support pipe).

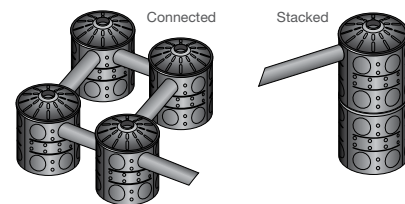

### Applications

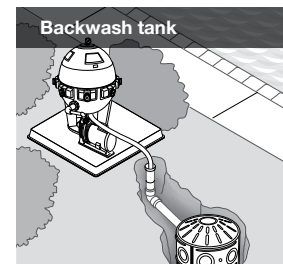
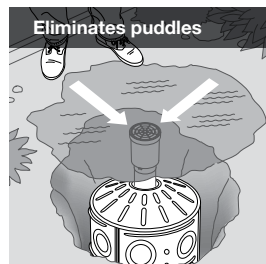
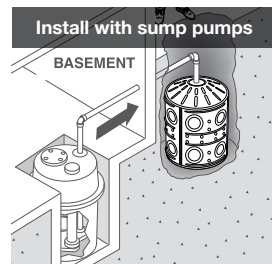
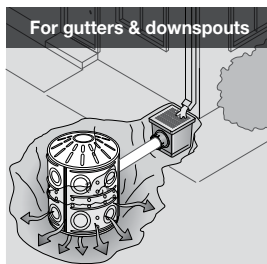

# EZflow®

Gravel-free installation provides up to 50% labor savings over traditional systems

- Better flow through & detention volume than traditional systems
- Durable with a 100-year lifespan
- Projects qualify for LEED credits
- EZflow is available in 3", 4" & 6" pipe sizes



## Over 150 Million Feet of EZflow® is in the Ground

### Performance Innovation

30-Sieve Geotextile Mesh

Geosynthetic Aggregate

ASTM F405 Rated  
Corrugated Pipe

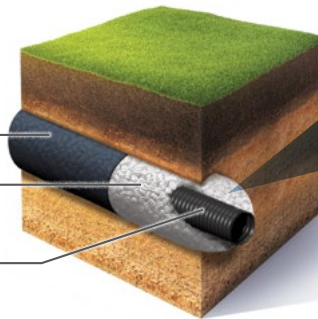

Engineered flow channels increase void space, creating improved water flow and greater storage.

Lightweight expanded polystyrene aggregate offers structural integrity and resists compaction.

## Install in Half the Time

Up to 50% labor savings. Gravel free installation.



Watch detailed installation videos at

[ndspro.com/videos](https://www.ndspro.com/videos)

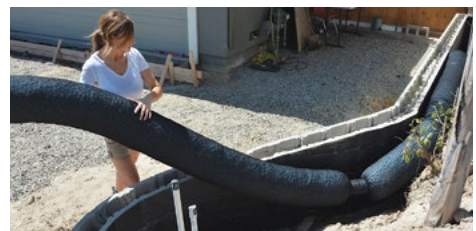

## Applications

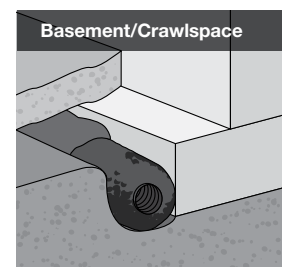
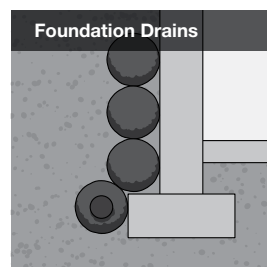
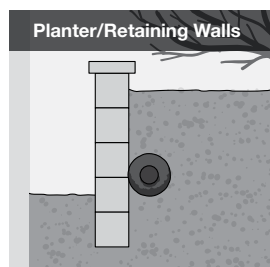
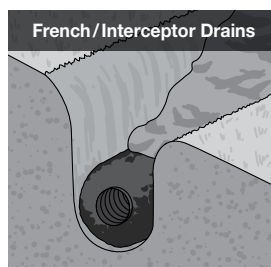



## Catch Basins & Grates

**NDS offers a complete line of catch basins and grates for residential and commercial stormwater management solutions.** NDS catch basins have sump areas that collect debris and prevent clogging of the pipeline, and grates are available in a variety of patterns and colors to blend in with surrounding surfaces. Depending on the size of the round, square, or atrium grates, they may fit directly into a riser of pipe, sewer and drain fitting, or our catch basins.

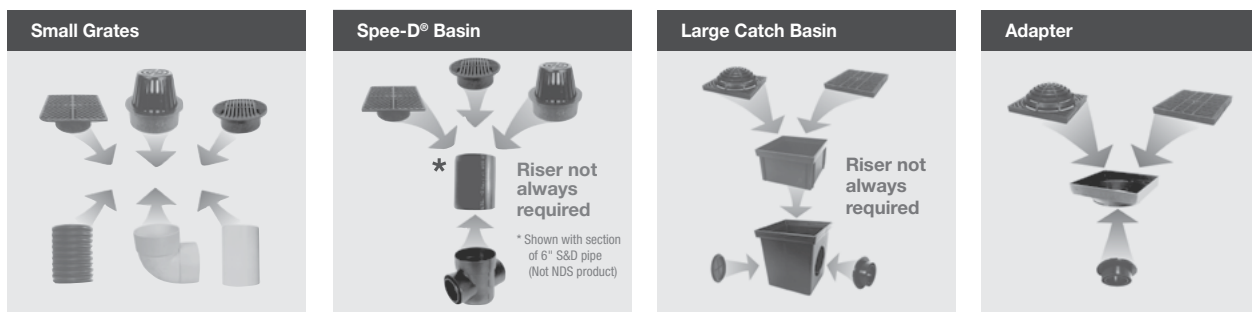

NDS catch basins and grates collect surface water while minimizing the amount of debris entering the system.

Available in a range of sizes from 6" round to 24" square, and with various grating and filter options for commercial and residential systems.



**6" Round**  
Spee-D Basin

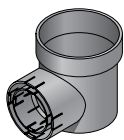

**9" Square**  
Catch Basin

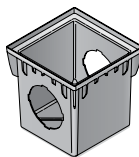

**12" Square**  
Catch Basin

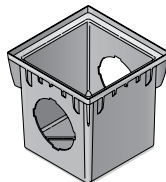

**18" Square**  
Catch Basin

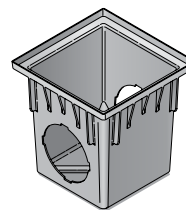

**24" Square**  
Catch Basin

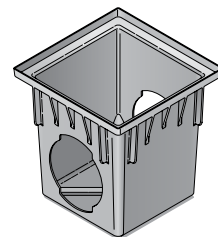

## Basin Filters

Adding a filter is a simple solution to keep water flowing through a drainage system, and a cost-effective alternative to expensive repair or replacement.

**Available for 9" and 12" catch basins.**

Grate holds the filter frame securely in place

Exploded view of installation



## Basin & Pipe Grates

NDS offers a variety of grates in sizes, patterns, colors and design options to fit all products and enhance any landscape. Available in plastic, iron, steel, brass & chrome, from sizes 3" round to 24" square, in standard slotted, flat, atrium style and even decorative patterns.



## Low Profile Adapters

Low-profile adapters offer increased open-surface area and flow capacity compared to a smaller grate matching the pipe diameter, and are also ideal in areas where there isn't enough depth for a full catch basin.

**Available in square sizes 9", 12" and 18".**

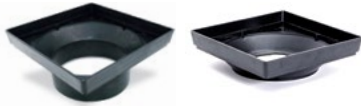

## Kits

Catch basins are available as complete kits. A convenient option that includes everything you need



# Pop-Up Emitters

The Pop-up Drainage Emitter is an easy, safe and efficient solution that allows water to be diverted and released to water-safe areas away from structures, erosion-prone landscapes and poor drainage areas.



## Channel & Trench Drains

NDS Channel and Trench Drain Systems provide durable and proven solutions for sheet-flow drainage in applications ranging from light foot traffic to heavy vehicular traffic.

NDS has the broadest line of Channel and Trench drains from 1" to 12" widths, available in profile-molded PVC, injection-molded polypropylene and even fiber-reinforced concrete. We have the products and support to get your job done right.



### Normal Widths From 1" to 12" in Plastic & Fiber Concrete

1" Micro Channel	6" Dura Slope
2" Slim Channel	8" Filcoten
3" Mini Channel	8" Pro Series
4" Filcoten	12" Filcoten
4" Spee-D Channel	12" Pro Series
5" Pro Series	

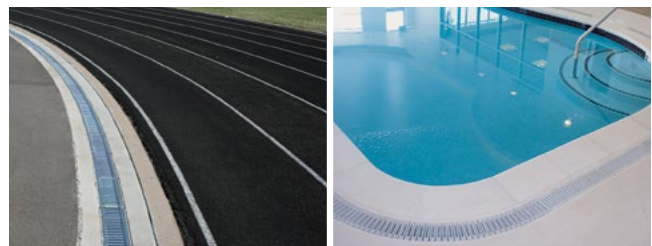

Radius couplings available for both 5" Pro Series and Dura Slope allow for large-radius or tight-turn channel and trench runs – **an NDS exclusive.**

### Channel Grate Materials & Styles

Our grates are available in a wide variety of styles, materials, colors and finishes.

#### Materials:

Plastic, Iron, Polished Brass, Satin Brass, Galvanized Steel & Stainless Steel

#### Decorative Patterns:

Mini & Spee-D: Botanical & Wave

Dura Slope: Weave, Diamond, Brick, Tile & Deco Slot

Plastic



Iron



Polished & Satin Brass



Galvanized Steel



Stainless Steel



Botanical



Wave



Weave



Diamond



Brick



Tile



Deco Slot



Slotted



Square



Chain





## FILCOTEN® Channel Drain

FILCOTEN® by NDS® combines smart engineering and smart materials to provide a superior trench drain suitable for handling a high-load capacity.

**4", 8" and 12" widths, sloped and neutral.**

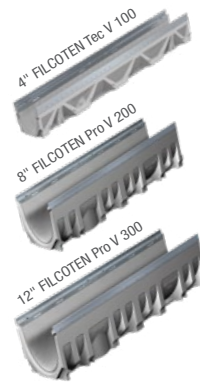

## Dura Slope™ Trench Drain

NDS Dura Slope™ is a high-quality quality, dependable, best-in-class trench drain system ideal for a variety of drainage solutions, including driveways, parking areas, warehouses, loading docks, pools, wash down areas and other areas for the interception and collection of surface runoff. Dura Slope pre-sloped and neutral trench drain system provides a solution for residential, commercial, industrial and municipal drainage needs.

**6" width, sloped and neutral.**

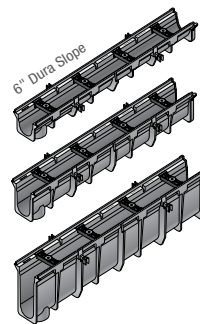

## Pro Series Channel Drain

NDS Pro Series is a lightweight channel drain system with interlocking joints and a modular design, so systems are flexible and connections are made quickly and easily.

Load Rated: Up to Class C with appropriate grate. For Residential and Commercial applications.

**3", 5", 8" and 12" widths.**

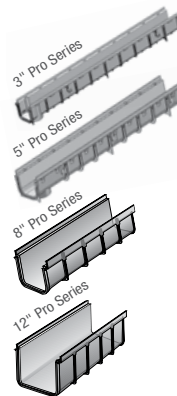

## Profile Channel Drain

Unique patented flying buttress design provides load-bearing support from both sides as well as underneath.

Available in four sizes. Spee-D® for driveways, large decks and commercial areas; Mini for landscapes, pools or decks; Slim for residential pools, spas and walkways and Micro for residential pools and spas.

Unique flanges on the bottom of the channel provide an anchoring lip for straight installation and prevents floating.

**1", 3" and 4" widths.**

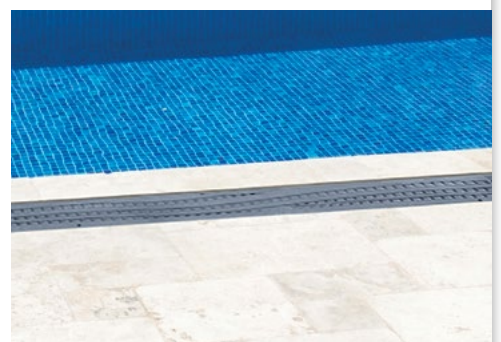
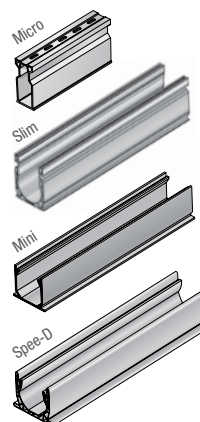

## NDS® StormChamber® Underground Stormwater Management



Offering superior strength, fast, easy installation and simple maintenance, NDS StormChamber is the most cost-effective chamber solution.

- Strong enough to withstand heavier loads like multi-axel trucks
- Able to be stacked or installed with deep cover
- Less parts, less excavation, less stone for lower construction costs.
- 100+ year lifespan



### Strength & Flexibility

**Thermo-formed High Density Weight Polyethylene HMWPE material won't crack.**

- Meets H-20 standards
- Up to 16' cover when deep installs are required for the 34". Up to 12' for the 44"
- Stack in 2 or 3 layers for high storage capacity in a small footprint



### Fast Installation

**Save time, money, and avoid extra excavation. Ideal for roadways, parking lots and fields.**

- Built in end walls
- No header pipe manifold system required
- Flexible design
- Lowest installed cost

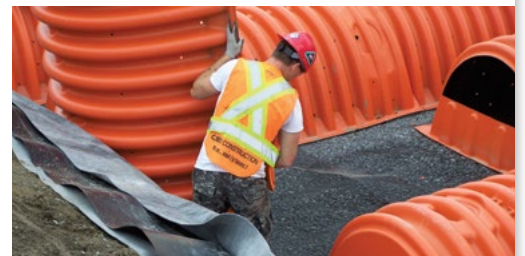

### Simple Maintenance

**Less time, less money and more forgiving.**

- Differentiated and centralized sediment control through our propriety SedimenTrap™
- SedimenTrap™ gathers sediments and other pollutants in one place for quick, easy and inexpensive removal by vacuum truck

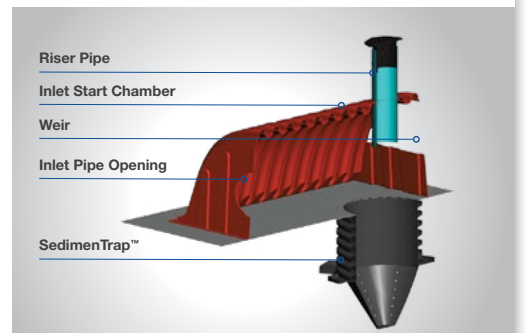

## Durability

### Longest life expectancy on the market.

- Withstands the most extreme environments
- Material bends instead of breaks giving it a brittleness temperature of -107°F vs. industry average of -2°F
- 100 Year Life Expectancy



## Stack

### Allows for deeper installation and a smaller footprint

- 34" Chambers: Capable of 3-layer stacking
- 44" Chambers: Contact NDS DesignWorx for any projects that may need stacking
- We offer expert site-specific design guidance based on 20 years of successful completion of projects



## NDS® StormChamber® Plan View

(Configuration Example)

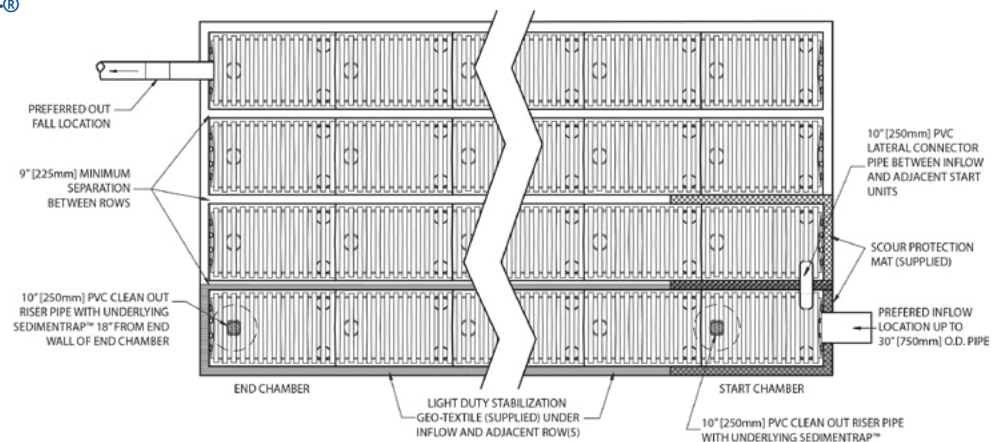

## See How StormChambers Stack Up

	StormChamber	Competition
Header Pipe Mainfold In Flow/Out Flow	Not Required	Required
AASHTO H-20/H-193 Wheel Loaded Rating	Exceeds Standard	Meets Standard
End Caps to Purchase and Install	Not Required	Required
Maximum Height of Fill	up to 16' (4877 mm)	8' (2440mm)
Clean-out Inspection	In Minutes	Slow
Multilayer Installations	Up to 3 Layers	Single Layer



## Grass & Gravel Paver Products

Permeable Pavers provide an alternative solution to traditional paving methods. Creating a strong grass or gravel surface that can support heavy vehicles, they maintain permeable surface areas, eliminating or reducing stormwater runoff.



### Benefits

**Greatest Compressive Strength\*.** Offering a high load-bearing capacity, NDS Permeable Pavers feature hexagonal cells that connect together to form a flexible grid system capable of handling significant structural loads.

**Easy Installation.** EZ Roll™ products come in large rolls that are easily placed and clipped together. Tufftrack™ features an integrated easy to assemble clip, that greatly reduces installation time.

**Reduced Maintenance.** Less expensive to maintain over time than traditional hardscaping and reduces demands put on landscape drainage systems.

**Environmentally Friendly.** NDS Permeable Pavers contribute to LEED credits and are made of up to 100% recycled plastic.

\*Compare the strength of NDS Permeable Pavers to the competition.

### EZ Roll™ Grass Paver Rolls

Available in:  
3.96 ft. x 24 ft. rolls – 97 square feet total  
3.96 ft. x 152 ft. rolls – 601.6 square feet total



### EZ Roll™ Gravel Paver Rolls

Available in:  
3.87 ft. x 149 ft. rolls – 577 square feet total

<b>Black</b> GP4X150	<b>Gray</b> GP4X150G	<b>Tan</b> GP4X150T	<b>Brick Red</b> GP4X150R
-------------------------	-------------------------	------------------------	------------------------------

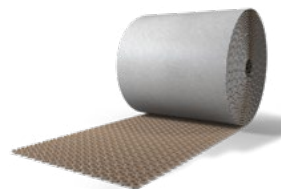

### Tufftrack™ Grassroad Paver Panels

Available in:  
24" x 24" panels, 1.5" thick

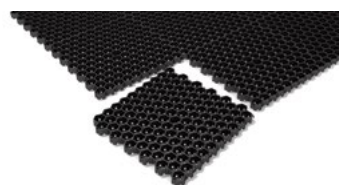

## Root Barrier Panels

Root barrier products direct root growth from shrubs and trees downward, dramatically decreasing the roots' potential to clash with and penetrate nearby hardscapes, walls, or building foundations. They provide protection against the high cost of reparations due to cracks in foundations and buckled sidewalks and driveways.



### Modular EP Series Root Barrier Panels

EP Series Root Barrier Panels are made from injection molded High Impact Polypropylene (HIPP) with a unique factory installed joiner strip that eases installation. EP Series Panels include a "T" top edge to prevent root overgrowth and an Anchor Lock™ external flange at the base to lock panels in the ground. Suitable for all planting installations, EP Series Root Barrier Panels are available in 12", 18", 24" and 36" depths.

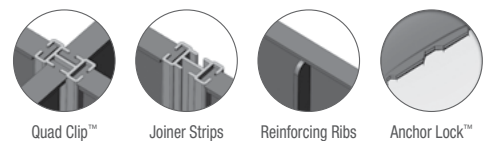

### Specifications

EP Series Root Barrier Panels by NDS include factory installed independent joiner strips. Each Barrier is a minimum of 0.090 inches thick and is made of up to 50% post consumer High Impact Polypropylene (HIPP) with U.V. inhibitors to ensure longevity. Barrier Panels have 1/2" raised vertical ribs running perpendicular to the panel and are 6" on center. All EP Series Panels feature a 3/8" wide "T" top edge and an external ground anchoring base flange that is 1/8" in width.

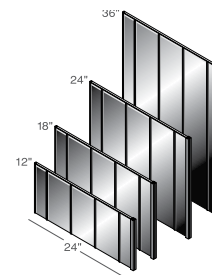

## Trunk Guards

Trunk Protector by NDS is made of Low Density linear Polyethylene (LDLPE) material with U.V. inhibitors to insure longevity. Trunk Protector measures 8" high, 12" wide and  $\pm 0.050$ " thick. Slotted vents are 1" high by 1/4" wide, creating a serrated lower edge on the bottom row.



## Root Barrier Planters

Root Barrier Planter by NDS has a top diameter of 22", a bottom diameter of 30", a height of 18" and a wall thickness of 0.250". Planter is one piece and molded of up to 505 post consumer Structural Foam High Impact Polyethylene (SFHIPP) material with U.V. inhibitors. Root Barrier Planter has a 3/4" inward facing top edge, a 1" external facing ground anchoring base flange with 1/2" high raised vertical ribs a  $\pm 6$ " intervals on the interior wall.

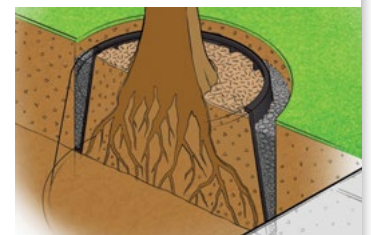



## Point Source & Dripline

Efficient drip irrigation products offer complete, system-oriented watering solutions for the green industry. Product offering includes drip emitters, multi-outlet devices, bubblers, micro-sprays, misters, tubing, fittings, stakes, regulators, valves, and filters.



### Point of Connection



### Adjustable Flow Rate Devices



### Pressure Regulation & Filtration



### Drip & Micro-Spray Emitters

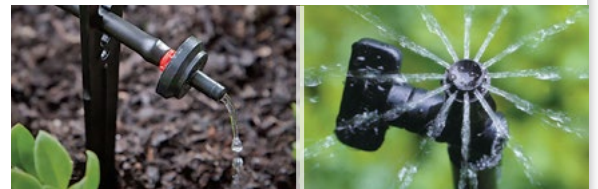

### Dripline



### Fittings & Accessories



### Single & Multi-Outlet devices



### Distribution Tubing





# Dura Flo™ Dripline & Accessories

## Dura Flo™ JR

Non-pressure compensating 1/4" dripline tubing.  
Ideal for small plantings, gardens and flower pots.

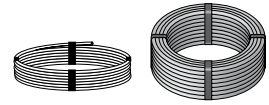

## Dura Flo™ PC

16mm, 17mm & 18mm pressure-compensating dripline  
for densely planted landscape applications.

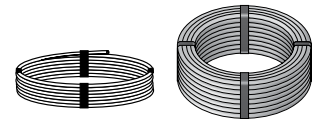

## Dura Flo™ CV

17mm & 18mm pressure-compensating dripline with check valve  
for densely planted landscape applications.

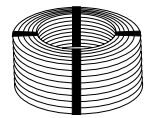

## Dura Flo™ HD

Heavy-duty, pressure-compensating, thick-walled 3/4" dripline  
for high-traffic commercial landscape applications.

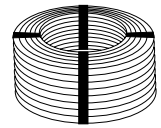

## Control Zone Kits

1-inch, 30 PSI and 40 PSI control zone kits with or without  
flow control. 40 PSI kit available in combo kit with valve box.

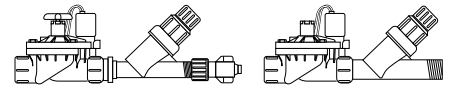

## Insert Fittings

1/4" and 1/2" insert drip-tubing fittings.



## Smart-Loc™ Fittings

Multi-diameter (16mm - 18mm) fittings up to 80 PSI pressure rating.



## Staples

Multiple styles, lengths and gauges.

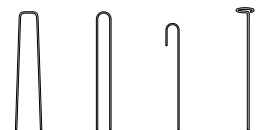

## Clamps

Pinch and worm-drive tubing clamps.



## Valve Boxes

NDS Valve and meter boxes are proudly manufactured in Lindsay, CA, and span a wide variety of sizes, from 6" round to 17" x 30" rectangular. Available with black, green, purple, gray, brown and sand covers with designations including irrigation control valve, water, sewer, electric, reclaimed water, cable TV, telephone and others. All NDS boxes and lids contain UV inhibitors for sustained durability and performance in direct sunlight.



### Standard Series Valve Boxes

Designed for residential and light commercial applications. Injection-molded of structural foam polyolefin.

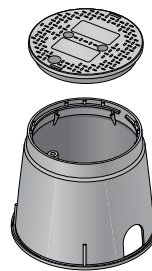

**Round**  
6" and 10"

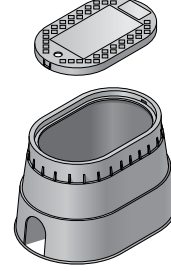

**Oval**  
8" x 14"



**Rectangle**  
10" x 15"  
14" x 19" Standard  
13" x 20" Jumbo  
13" x 24" Super Jumbo

### Specification Series Valve Boxes

#### Pro Series & Pro Series Plus

Designed for commercial applications. Injection-molded of high-impact, high-density structural foam polyethylene.

Custom lid inserts available for large opportunities.

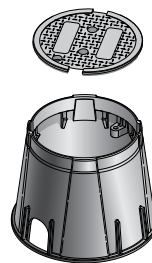

**Round**  
6" and 10"

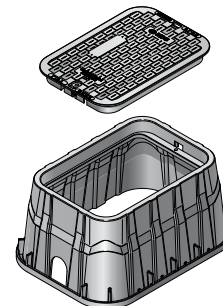

**Rectangle**  
14" x 19" Standard  
13" x 20" Jumbo  
13" x 24"  
17" x 30"

# Meter Boxes

Designed specifically for the Automatic Meter reading industry, the newest line of AMR boxes builds on the NDS tradition of strength, durability and value.

Like our current automatic Meter Reading products, this new line of AMR boxes and covers are injection-molded of polyolefins and contain UV inhibitors to prevent discoloration and cracking.



## Meter Boxes

Superior signal transmission versus products made of concrete materials or cast iron.

Lighter weight material eases installation and lowers freight and handling costs.

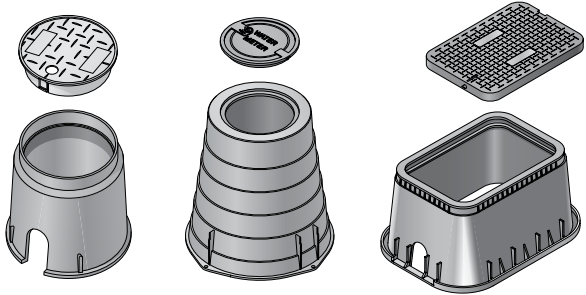

Round	Round Pit	Rectangle
6" and 10"	18" and 24"	10" x 15" 14" x 19" Standard 13" x 20" 13" x 24" 17" x 30"

## Bottom Mounts

- Concealed antennae are completely protected from landscape equipment damage and are less likely to draw attention from vandals
- Exceptional antennae signal transmissions
- Offset cavities eliminate the physical interference between antennae and meter
- Bracket accommodates a majority of the industry antennae

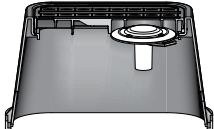

Single AMR bottom mount (pre-assembled bracket)

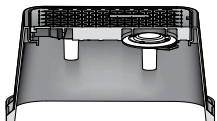

Double AMR bottom mount (pre-assembled bracket)

## Top Mounts

- Recess reduces the probability of damage caused by landscape equipment & vandals
- Offset recesses eliminate the physical interference between the antennae & meter
- Recess and holes accommodate most of the industry antennae
- Compatible with many of the industry Touch Read antennae



Single AMR top mount

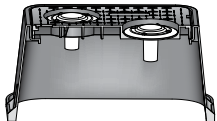

Double AMR top mount



# From NDS®

## The Leader in Stormwater Management

### Are You a Drainage Contractor?

Do you actively promote drainage solutions to your customers and feature drainage on your website?

Are you looking to learn more about drainage and grow your drainage business?

If you answered yes to any of the above, email [NDSmarketing@ndspro.com](mailto:NDSmarketing@ndspro.com) to see how we can help.

### Visit [ndspro.com](https://ndspro.com) for:



Videos



Tools/  
Calculators



Downloads



Case  
Studies



Design  
Worx



Request  
a Quote