

NDS FLEXIBLE SADDLES

NDS Flexible Saddle

For superior durability and flexibility, saddle up.

A breakthrough in saddle design, the patented NDS Flexible Saddle demonstrates superior flexibility in more than one way. The saddle's elastomeric construction allows a single description to securely fit 6" sewer main pipe diameters and up. The saddle's flexibility eliminates the need for a large inventory of rigid PVC saddles of various descriptions.

NDS Flexible Saddle offers the following product benefits:

- Two configurations, a "Tee" and a "Wye" are available in 4" or 6" inlet descriptions
- Elastomeric construction provides maximum strength and flexibility
- Saddle design will accommodate polyethylene pipe used in slip lining sewer systems
- Inlet range from SCH-40 down to SDR-35 includes standard weight soil pipe
- Stainless steel series 300 clamps ensure tight seal
- Steel reinforced edges prevent distortion when torque is applied to clamps
- Durable design and low unit price make the Flexible Saddle economical and environmentally wise
- Available saddle blanket, attached to pipe prior to saddle installation, will mend imperfections and cracks on clay pipe taps

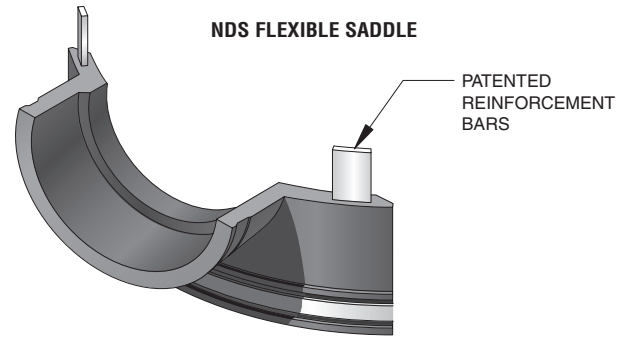

NDS Flexible Saddles

	Part No.	Description	Color	Pkg. Qty.	Wt. Ea. (lbs.)	Product Class
	4T/C	4" Tees w/ Clamps	Black	12	3.16	45FS
	4T/WOC	4" Tees w/o Clamps	Black	12	2.66	45FS
	4Y/C	4" Wyes w/ Clamps	Black	6	7.66	45FS
	4Y/WOC	4" Wyes w/o Clamps	Black	6	7.12	45FS
	6T/C	6" Tees w/ Clamps	Black	6	6.50	45FS
	6T/WOC	6" Tees w/o Clamps	Black	6	6.00	45FS
	6Y/C	6" Wyes w/ Clamps	Black	4	12.25	45FS

Saddle Clamps

Part No.	Description	Color	Pkg. Qty.	Wt. Ea. (lbs.)	Product Class
33S248 CLAMP	Clamp for Flexible Coupling	Stainless Steel	100	0.25	45FS

ASTM Material Specification

Test	NDS Material	ASTM Test Material
Chemical Resistance 1N sulfuric acid 1N hydrochloric acid	No weight loss No weight loss	D543
Tensile Strength Elongation	1000 psi (7/Mpa) min; 200% min. elongation @ break	D412 Die "C"
Duration Hardness	Shore durometer 50 min. to 75 max	D2240
Compression Set	30% max of original deflection	D395, Method B Type 2
Water Absorption	5% max	D471, immersed 7 days @158 Method A
Ozone Resistance	No visible cracking under 7x magnification	D1149, D518 Method A
Oven Aging	75% min of original tensile strength. 65% min of original elongation	D573 (158°F for 70 hours)
Cold Brittleness	Cold brittleness was determined to be -43°C	D476
Tear Strength	125 lbs./in.	D624 Die "C"

Note: All dimensions are nominal. All weights are for shipping purposes only. Availability is subject to change.

NDS FLEXIBLE SADDLES

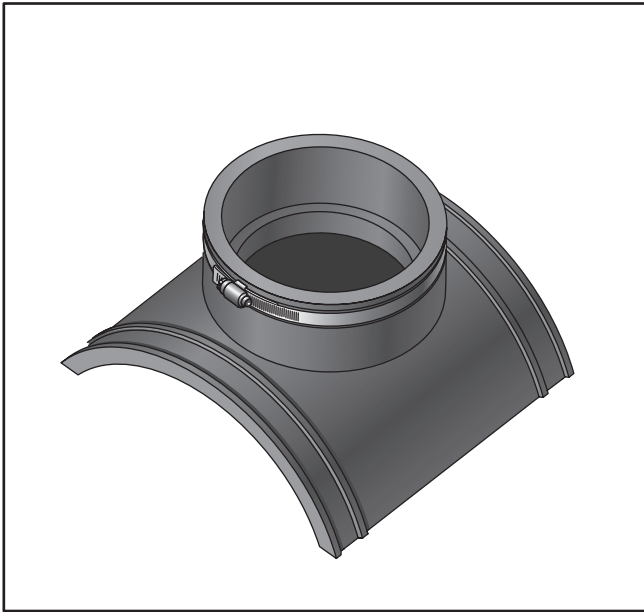

STEP 1: Standard saddle

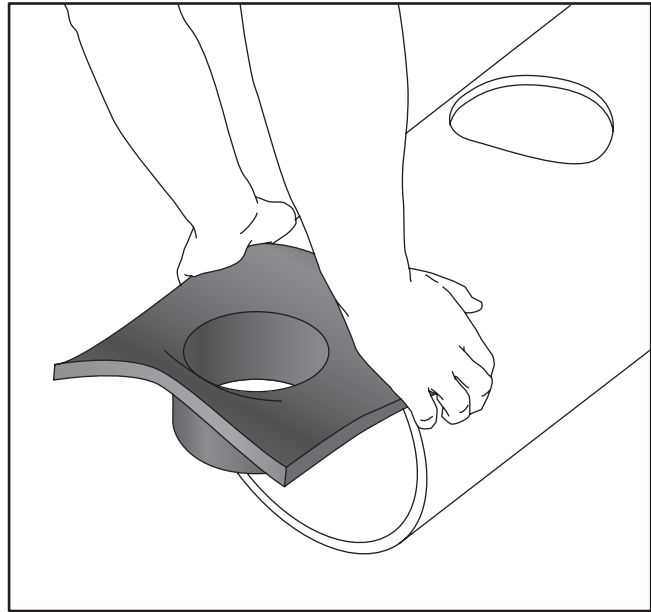

STEP 2: Invert saddle and press down against the curvature of the pipe to obtain the correct deflection of the skirt as illustrated.

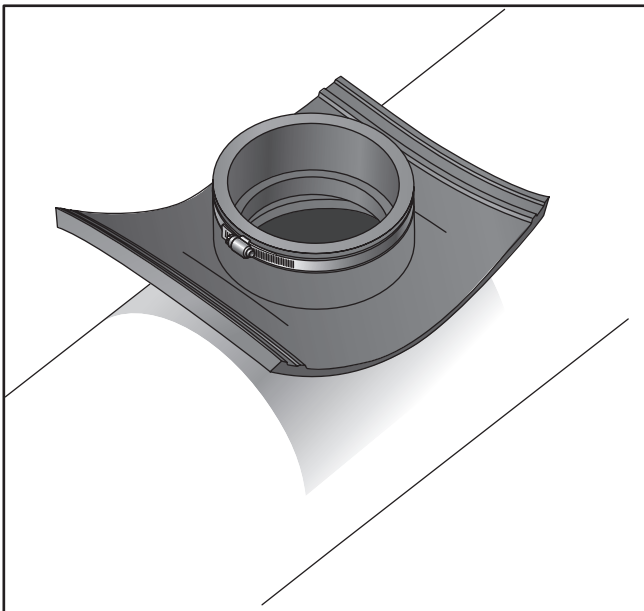

STEP 3: Locate the saddle with the deflected skirt over the tap hole.

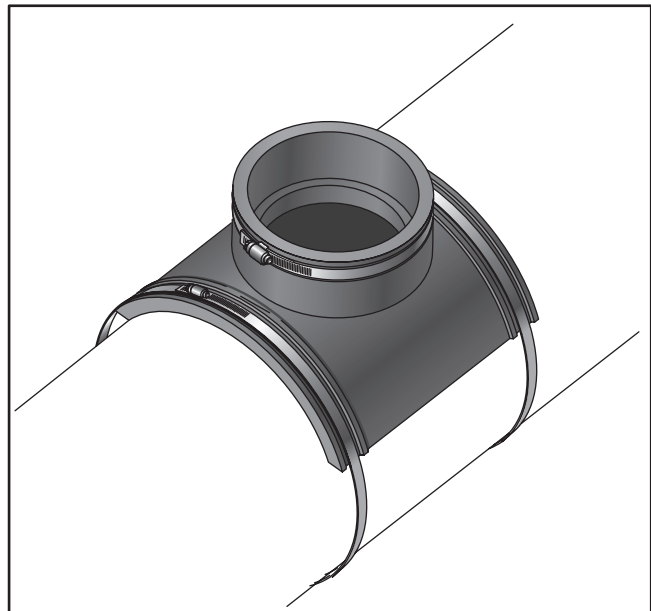

STEP 4: Tighten clamps to a minimum of 60 inch-Lbs torque (5ft-Lbs torque). Bed and backfill according to engineer's specifications.

Note: All dimensions are nominal. All weights are for shipping purposes only. Availability is subject to change.