

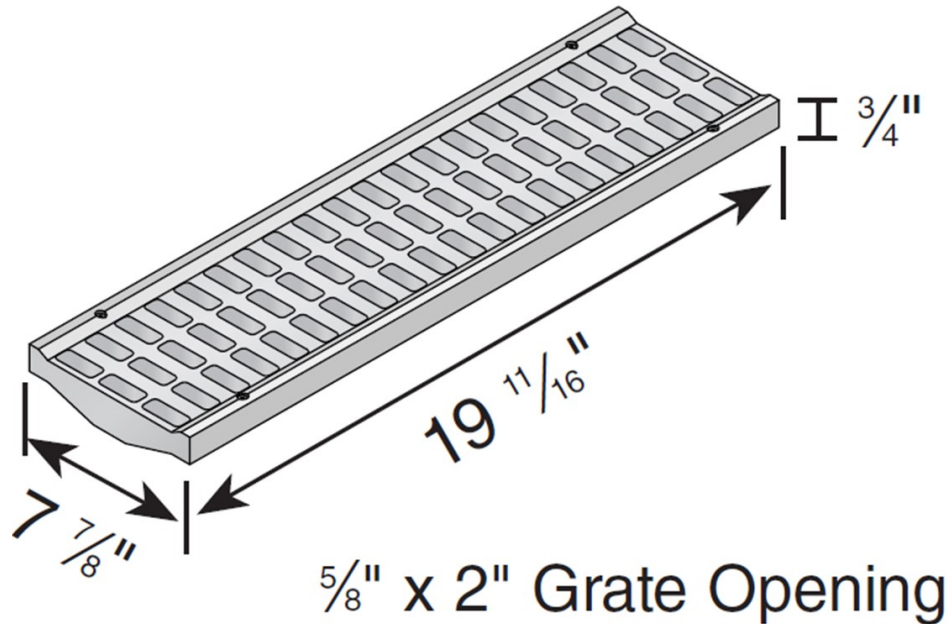

TECHNICAL SPECIFICATION



PART NUMBER	SIZE	GRATE OPENING	LOAD CLASS	OPEN AREA FLOW RATE W/ 1/2" HEAD	WEIGHT	ADA	HEEL PROOF
837	7-7/8" X 19-11/16" X 3/4"	5/8" X 2"	B	30.28 IN ² 92.63GPM / LF	3 LBS	NO	NO

SPECIFICATION:

MATERIAL: HDPE

LOAD CLASS B—LOADS OF 61-175 PSI. RECOMMENDED FOR MEDIUM-DUTY PNEUMATIC TIRE TRAFFIC, AUTOS AND LIGHT TRUCKS AT SPEEDS LESS THAN 20 MPH.

REQUIRES #829 (4) PER GRATE

FITS 8" PRO SERIES CHANNEL

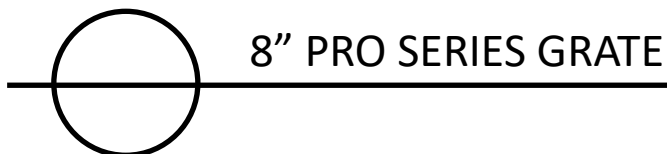

FOR PRODUCT ASSISTANCE, CONTACT NDS TECHNICAL SERVICE AT techservice@ndspro.com, DESIGN ASSISTANCE- designworx@ndspro.com

851 N. HARVARD AVE. LINDSAY, CA 93247 WWW.NDSPRO.COM 1-800-726-1994